

SECTION J-J
SCALE 1/8

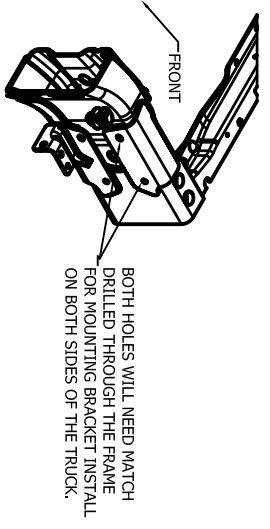

CHASSIS FRAME BEHIND CAB
SCALE 1/8

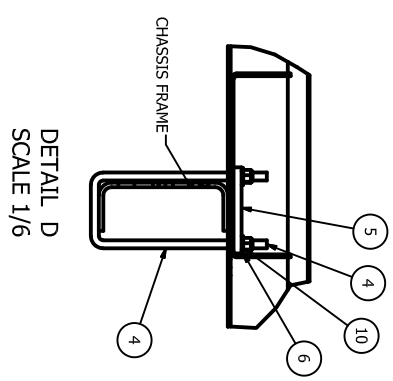
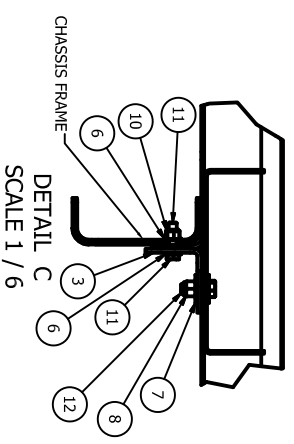

INCLUDE A COPY OF THIS DRAWING

ITEM	QTY	DMG ID	PART NUMBER	DESCRIPTION
14	12	927190	927190	1/2" PLASTIC HOLE PLUG, CMPPT BTM
13	1	0900	144403-03	PLASTIC PARTS BAG, 8" X 12"
12	2	9170	917516	SCREW 5/8-11 X 1.75 GR 8 HHCS
11	4	9170	917475	HHCS 1/2-13 X 2.00 GRD.8
10	8	9190	144736	NUT-1-K-1/2-13 GR8
9	10	9170	134270	5/8-11 X 2.00 GRADE#8 HHCS
8	12	9190	919526	NUT, 5/8-11 NYLON LOCK GR 8
7	24	9190	919880	WASHER 5/8 FLAT
6	12	9190	129115	1/2 WASHER - HARDENED
5	2	0900	216877	THE STRAP U-BOLTS
4	2	9330	216876	U-BOLT-1-0.501D X 4.25" CE X 1.1"
3	2	4233	228808	BRACKET-2017 FORD FRONT MNTG
2	1	4233	228821-02	BRACKET-REAR MOUNTING-RH
1	1	4233	228821-01	BRACKET-REAR MOUNTING-LH

TITLE
CST 134 INSTALLATION-17 FORD

DATE 11-21-16
SCALE 1=16
DMG ID 4233

RAW MNT CODE / **SHEAR SIZE OR PURCH. DATA** / **TYPE CODE** 1 / **UM** EA

STAHLL
 A SCOTT-FETZER COMPANY
 209370-17-84CA